



Insulated Structures

Efficiency At Work

SQUARE GLASS AMBIENT – Linear 2



Standard Specifications
• 1 x LED Lit Glass Shelves
• Stepped bottom Pan
• Linear Front Bars
• Rear Sliders
• Powder Coated Cladding

Optional Specifications
• 20mm Glass Patch Ends with Black Capping
• Solid Color Coded patch Ends
• Removable Front Riser Glass
• Cladding Options: Refer to Cladding Details Document (Available on Request)

Leaders in world class innovation for bespoke end to end energy efficient refrigeration solutions



Insulated Structures
Efficiency At Work



Insulated Structures

Efficiency At Work

SQUARE GLASS AMBIENT – Linear 2

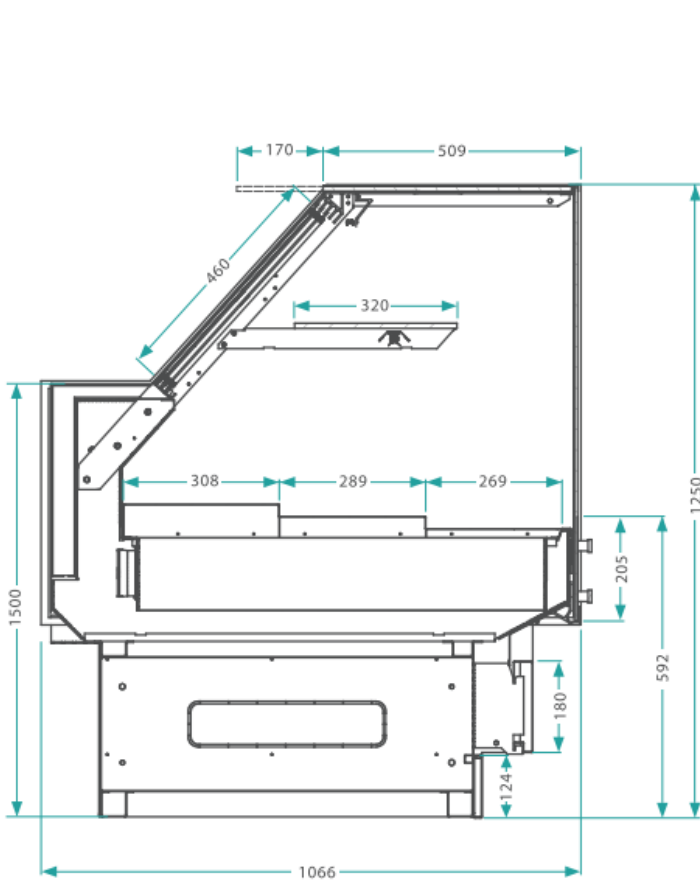

SIDE SECTION VIEW

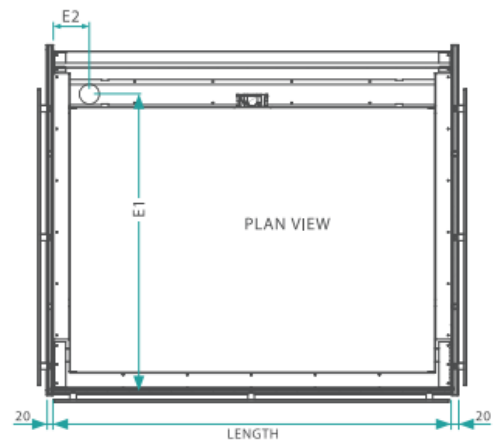
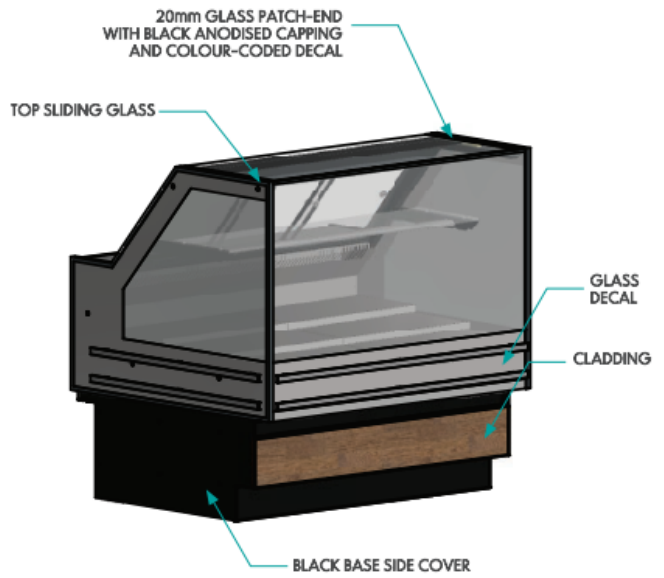

Physical Properties		
Size	Length (m)	TDA (m ²)
4ft	1.218	1.13
6ft	1.828	1.72
8ft	2.440	2.30
12ft	3.660	3.47

Drain and Refrigeration Points					
D1	D2	D3	D4	E1	E2
-	-	-	-	800mm	110mm
-	-	-	-	800mm	110mm
-	-	-	-	800mm	110mm
-	-	-	-	800mm	110mm

Electrical Specifications		
Circulations Fan EBM 3656	Lighting Case (LED)	Lighting Shelf (LED)
1x12W	1x16W	1x16W
1x12W	1x25W	1x25W
2x12W	2x16W	2x16W
2x12W	3x16W	3x16W

Leaders in world class innovation for bespoke end to end energy efficient refrigeration solutions



Insulated Structures
Efficiency At Work